



Oasis Clearwater
ENVIRONMENTAL SYSTEMS



OWNER OPERATION MANUAL

CLEARWATER Z54 DELUXE

PLEASE READ

We urge you to fully read this Manual. The contents are important to your safety and the operation of the Clearwater Z54 Deluxe Treatment System.

Keep this Manual with other important household manuals for future reference.

If you have questions regarding the safety and operation of your Clearwater Z54 Deluxe Treatment System, contact your Local Authorised Service Technician.

- Do not attempt to service components of the system yourself, call your Accredited Service Technician.
- Only Authorised Service Personnel are to remove covers on the Treatment System.

CONTENTS

CLEARWATER Z54 DELUXE SYSTEM OPERATION	2
INTRODUCING PRODUCTS INTO THE SYSTEM	3
SYSTEM MAINTENANCE, MONITORING AND SERVICING	6
TROUBLE SHOOTING – PROCESS FAILURE	7
LIMITED WARRANTY	8
INSTALLATION AND EXCAVATION DETAILS.....	9
ELECTRICAL REQUIREMENTS.....	10
SYSTEM MAINTENANCE – CANTERBURY AREA.....	13

INTRODUCTION

The system normally comprises 2 or 3 separate chambers (gravity or pumped system).

The system comprises a pre-treatment chamber (of 3,560 litres) gravity feeding to a second chamber that provides Primary Treatment (1,280 litres) incorporating a Zabel A100/300 filter.

If a pump is incorporated into the system, the pump well has a capacity of 700 litres. Various pumps can be fitted to the system depending on duty requirements.

The system may also be fitted with an electrical isolator switch and high water level audible alarm, mounted on a post on the system, in the event of system malfunction.

INTRODUCING PRODUCTS INTO THE SYSTEM

Introducing harmful products into the system may reduce the efficiency of the system or stop the treatment process by destroying the bacteria. These products that reduce the efficiency or stop the treatment process can be grouped into two groups, prohibited substances and limited-use substances. While the wastewater treatment system will process most waste produced by the average household, the following information will maximise the system's efficiency and reduce the time period between primary chamber pump-outs.

NOTICE: Introducing harmful or damaging chemicals into your Clearwater Z54 Deluxe System may void the Warranty.



A. Prohibited Substances:

These substances are detrimental to the system's ability to process wastewater, even when present in small amounts. Prohibited substances include but are not limited to the following:

Do not introduce the following prohibited substances into your Clearwater Z54 System:

- ✘ Plastic or rubber products, petroleum products, such as motor oil, paint, paint thinner, petrol and solvents
- ✘ Non-biodegradable products, such as sanitary napkins, condoms and disposable napkins
- ✘ Toxic substances such as pesticides, strong disinfectants and strong caustic drain cleaners
- ✘ Large amounts of paper products, such as paper towels and synthetic fibre-reinforced products advertised as having "wet strength"
- ✘ Animal fats, such as bacon grease or lard (normal cleaning of pots and pans is acceptable).

Chemicals

The following chemicals are prohibited substances and **should not be** poured into the Treatment System:

- ✘ Herbicides
- ✘ Pesticides
- ✘ Paint
- ✘ Thinner
- ✘ Motor Oil

Have you read the "Essential Guidelines"?

(enclosed with your system information)



B. Limited-Use Substances:

Limited-Use substances in large concentrations will reduce or stop the treatment process. The same substances in smaller concentrations will have no harmful effect on the treatment process. You may use the following substances without harming your Clearwater Z54 Deluxe Treatment System if you use the substance according to the manufacturer's directions, use the substances SPARINGLY, and do not introduce concentrated doses into the system:

- ⚠ Bio-degradable laundry powders
- ⚠ Laundry Bleach
- ⚠ Detergents with Bleach

Household cleaners containing sodium bactericides such as:

- ⚠ Pine oil (disinfectant used in general purpose liquid cleaners)
- ⚠ N-alkyl dichlorobenzyl ammonium chloride (disinfectant used in detergents and spray cleaners)
- ⚠ Sodium hydroxide (LYE chemical used in drain openers and cleaners)
- ⚠ Sodium dichlor-s-triazinetrione (powdered bleach used in scouring powders and automatic dishwasher detergents)
- ⚠ Ortho-phenylphenol (bactericide used in tub and toilet bowl cleaners)

Waste Food

Some food waste, whether or not it is run through a waste grinder will not be treated by the system, but will remain in solid form and fall to the bottom of the septic tank. Therefore, you should consider not using a waste grinder system, or disposing of these food items through the Clearwater Z54 Deluxe Treatment System:

- ✘ Animal Bones
- ✘ Melon Rinds
- ✘ Corn Cobs
- ✘ Pips and Seeds
- ✘ Eggshells
- ✘ Any other non-edible food waste



C. Acceptable Substances:

Substances that are considered to be typical domestic wastewater are human waste, bath and dish water and edible food waste.

The following substances may be used regularly without harming your Clearwater Z54 Deluxe Wastewater Treatment System:

- ✓ Laundry detergents without bleach
- ✓ Dishwashing detergents without bleach
- ✓ Toilet Paper
- ✓ Household cleaners containing sodium bicarbonate, sodium carbonate and sodium borate.

SYSTEM MAINTENANCE, MONITORING AND SERVICING

The Clearwater Z54 Deluxe is available as either a gravity fed or dosed pump system. The owner should determine the status of the system, substances introduced into the system, and the frequency of required pump-out as determined by the service provider.

Your Clearwater Z54 Deluxe System can be furnished with an annual service policy to ensure proper operation of the system.

Primary and Secondary Chamber:

Periodically, waste will need to be removed from both chambers using normal pump-out procedures.

Zabel A100/300 Filter:

The system is complete with a Zabel bacteriological filter which performs two primary functions in a septic tank installation. It retains and filters 75% of all suspended solids in the tank and treats the wastewater by lowering the BOD5 more than 50%.

Dosed Pumping System:

A dosed pumping system is used to give a proportioned controlled flow to the engineered designed disposal field, to allow for even distribution over the entire field. Submersible effluent pumps operate in harsh acidic conditions and should be checked on a regular basis for satisfactory operation.

System Capacity:

The system is rated for a maximum of 8-10 persons or 1,800 litres per day. As with any system it is important the system is not hydraulically overloaded as this will interfere with the organic breakdown of the treatment process.

Visual:

Wastewater backup is characterised by wastewater flowing back into the house or slow movement of wastewater in the drains. This may indicate a problem with your wastewater treatment system. Identify where the backup is occurring within your home's plumbing system. If no material is blocking the drain, contact you Service Technician or local supplier.

TROUBLE SHOOTING - PROCESS FAILURE

Problem	Possible Causes	Solutions
Audible alarm on control panel is ringing	The pump has failed, or is blocked	Remove pump from system and determine if inlet is blocked or complete pump failure has occurred.
Wastewater is backing up into the home sewer piping.	There is an obstruction in the home sewer piping.	Check the piping lead to the system visually or with drain cleaning equipment for an obstruction and correct.
	There is an obstruction in the discharge line from the system.	Check the effluent piping and lateral field piping visually or with drain cleaning equipment for an obstruction, and correct.
	The lateral field pump has failed.	Check the operation of the lateral field pump per the manufacturer's specifications.
	The flow rate to the system is too high.	Check the maximum flow rate to the system to see that it is within normal limits.
	The tank requires cleaning and/or a pumpout is required.	Check the sludge depth in both chambers of the tank to see if it is below required levels.
	Zabel filter has blocked.	Remove Zabel filter from system and clean as necessary.

LIMITED WARRANTY

Oasis Clearwater Systems warrants each Clearwater Z54 Deluxe Treatment System to be free from defects in material and workmanship for a period as follows:

- (a) Concrete structure = 10 years
- (b) Electrical and mechanical componentry = 12 months
- (c) Zabel filter = Lifetime Warranty

From the date of the sale to the ultimate consumer when properly registered with Oasis Clearwater Systems. Oasis Clearwater System's sole obligation under this warranty is as follows:-

Oasis Clearwater Systems shall fulfill this warranty by repairing or exchanging any component part, F.O.B. factory, that shows evidence of defects, provided said component part has been paid for, warrantee has notified Oasis Clearwater Systems of the defect complained of and the component is returned through an authorised Distributor, transportation paid. There is no informal dispute settlement available under this LIMITED WARRANTY.

The warranty does not allow for labour or travel.

The warranty does not cover Oasis Clearwater Treatment plants and related components that have flooded, by external means, or that have been disassembled by unauthorised persons, improperly installed, subject to external damage or damage due to altered or improper wiring or overload protection.

Other than the mechanical and structural working of the plant itself, Oasis Clearwater Systems is not responsible for the in-field operation of a plant. The proper operation of this or any other individual wastewater plant depends upon proper organic and hydraulic loading of the plant. We cannot control the loading and thereby cannot control the amount of harmful substances that may be discharged into the plant. Only the users of a plant can control what enters the unit. Therefore, we provide a comprehensive user's manual that outlines substances that should be kept out of the plant.

This LIMITED WARRANTY extends to the ultimate consumer of the product. As herein "ultimate consumer" is defined as the purchaser who first had the plant installed, or in the case of a system designed for non-permanent installation, the purchaser who first uses the system. It is the purchaser's or any sub-vendee's obligation to make known to any other consumer, the terms and conditions of this warranty.

This warranty is a LIMITED WARRANTY and no claim of any nature shall be made against Oasis Clearwater Systems unless and until the ultimate consumer, or his legal representative, notifies Oasis Clearwater Systems in writing of the defect complained of and delivers the product and/or defective part(s) freight prepaid, to Oasis Clearwater Systems or an authorised agent.

Oasis Clearwater Systems reserves the right to revise, change or modify the construction and design of the Clearwater Z54 Deluxe Treatment System, or any component part or parts thereof, without incurring any obligation to make such changes or modifications in equipment previously sold. Oasis Clearwater Systems also reserves the right, in making replacements of component parts under this warranty to furnish a component part which, in its judgement is equivalent to the part replaced.

INSTALLATION AND EXCAVATION DETAILS

Excavation Dimensions Clearwater Z54 Deluxe Unit 4 metres x 2.5 metres x 1.5 metres (Less optional extension turrets)

The tank access lids should be 100mm above ground level (fitted with risers if necessary), to prevent stormwater and rainfall getting in, and be able to be easily accessed by servicemen.

Tank Dimensions

- 3.000m Long
- 2.000m Wide at Anti floatation feet
- 1.550m High
- 1.320m To Invert from base of tank
- 0.230m To Invert from top of Lid

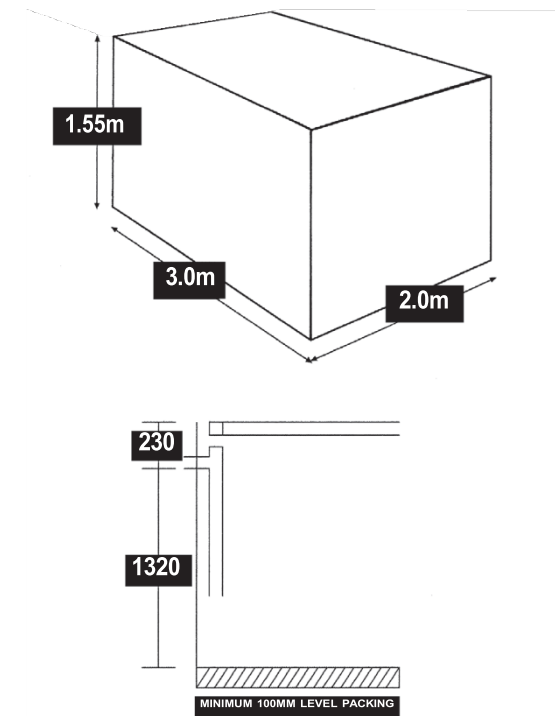

ELECTRICAL REQUIREMENTS

Oasis Z54 tank controller installation guide

Refer to attached wiring and circuit diagram when installing the controller. All electrical work must be carried out as per NZS 3000:2007 and NZECP2:1993. The controller is to be earthed at the distribution board and the supply to the controller should be protected by its own dedicated 16Amp 30mA RCD or as required. Any questions during installation please contact N2P Controls on 09 570 1919.

This controller is rated to 4A at 230V and has been designed for the Z54 pumps only.

1. Remove the cover from the controller.
2. Refer to wiring diagram to side. Wire the supply Earth, Neutral and Phase to the bottom 3 terminals.
3. Wire the pump's phase, neutral and earth terminals to the next 3 terminals.
4. Wire the high level alarm float to the terminals labelled *Alarm NO (Brown Wire)* and *Alarm NO (Black Wire)*. The float is to be wired Normally Open (NO). The blue wire is not used and can be wired to the *Alarm Not Used (Blue Wire)* terminal. The level float is low voltage.
5. NOTE: The ON/OFF switch is to turn power on and off to the pump and printed circuit board only.
6. Once installed commission by:
 - Power controller – Green Power LED light should illuminate on front.
 - Test pump by lifting the float attached to the pump.
 - Test high level alarm by lifting high level alarm float. The red *Fault* LED should illuminate, buzzer sound and alarm light flash.
 - Press the mute button and the buzzer shall stop.

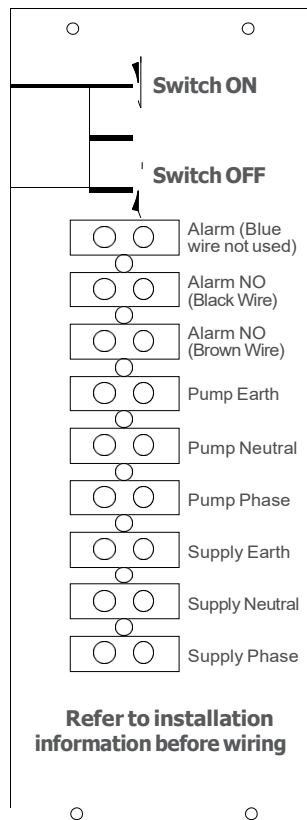

Mute Options

There are three different mute options; Continuous, Chirp and Auto.

Continuous – The buzzer will sound continuously until the mute button is pushed. It will stay muted until the next alarm state occurs

Chirp – The buzzer will sound continuously until the mute button is pushed. Once the mute button is pushed, the buzzer will sound for one second every 10 minutes until the fault is cleared.

Auto – The buzzer will sound continuously until 30 minutes have passed and then the buzzer then will automatically mute.

The different mute options are changed by moving the link on the PCB highlighted below.

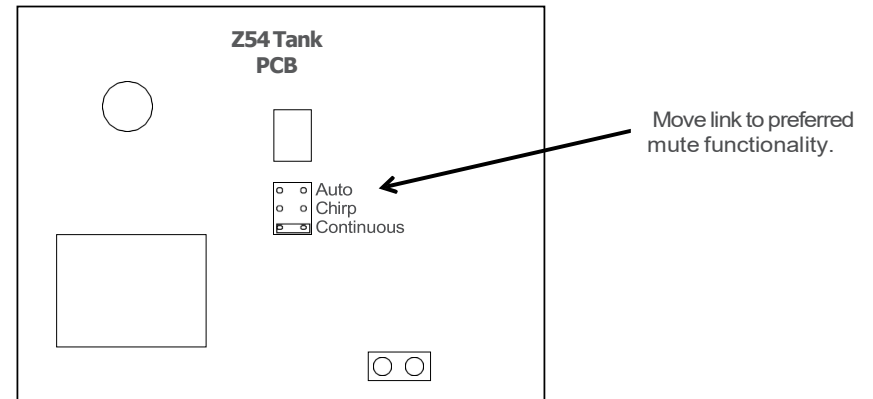

SYSTEM MAINTENANCE, MONITORING AND SERVICE

Alarm Light

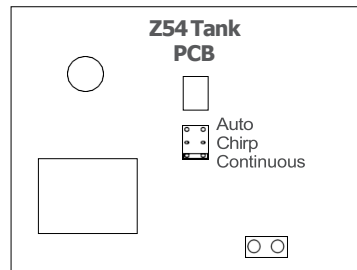

Neutral
240VAC

Float
Input

Switch
(4A Inductive Load)

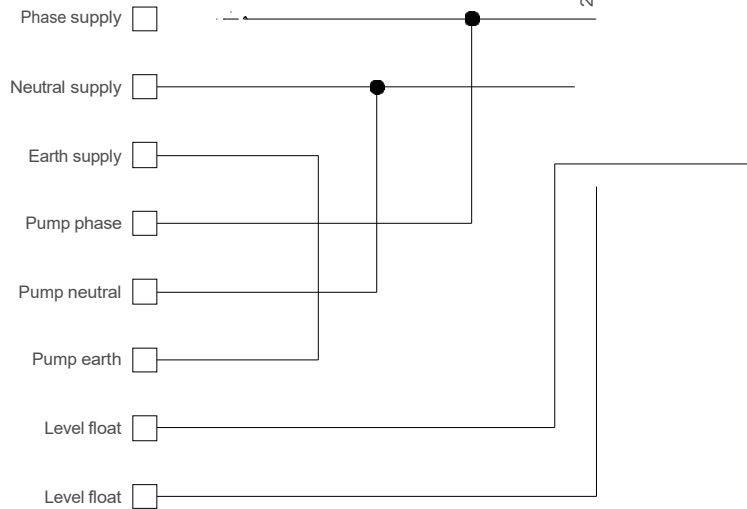

Within the greater Canterbury area, Oasis Clearwater Systems offer an annual service and maintenance contract to ensure your system functions correctly.

Service procedure includes the following:

1. Visual inspection of system to ensure correct biological function of system.
2. Septic and secondary chamber checked and biological breakdown of sewage analysed for correct operation of system. Client notified of correct timing for septic pump-out.
3. Zabel bacteriological filter cleaned and repositioned as necessary.
4. If pump fitted, unit removed, screen removed, impeller checked and unit fully cleaned of debris/build-up.
5. Field service report presented to owner and council where applicable verifying work carried out.

oasisclearwater.co.nz

Head Office

A PO Box 16276 Hornby, Christchurch 8441

P 0800 48 48 49

F 03 344 0267

E office@oasisclearwater.co.nz

W oasisclearwater.co.nz

